

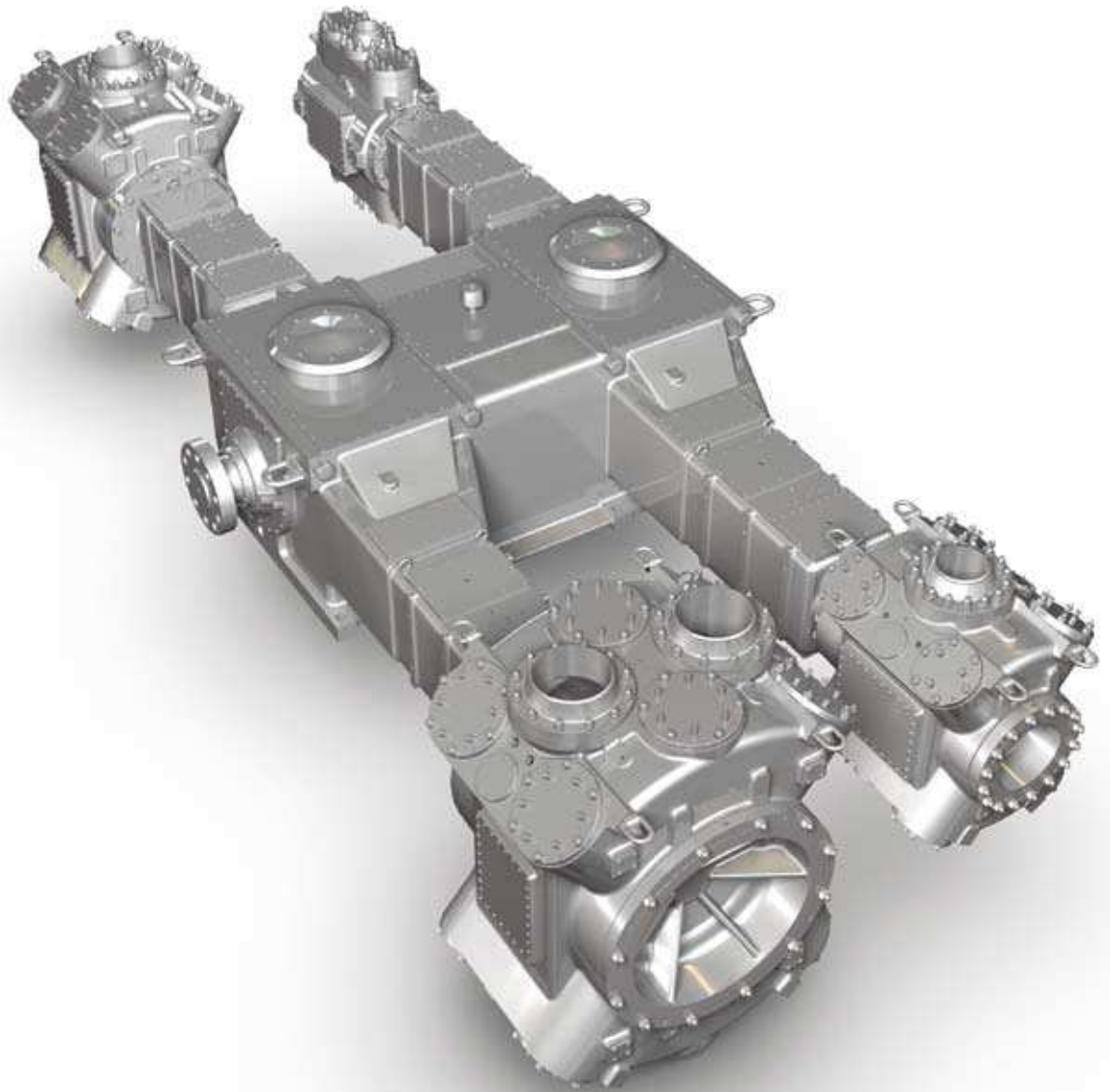

Burckhardt Compression

Process Gas Compressors

API 618 – Reliable Swiss Quality



Markets and Applications – From Processing Applications to Natural Gas Services



Refinery

- Hydrotreatment
- Hydrodesulphurisation
- Hydrocracking
- Fractionating
- Reforming
- Catalytic cracking

Gases handled – corrosive, explosive or toxic

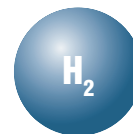



Industrial gases

- Hydrogen generation
- Air separation
- Gas bottle filling

Petrochemical/Chemical industry

- Polyolefins
- Aromatics/BTX
- Alcohols
- Ammonia
- Urea
- Polyethylene
- Ethylene oxide
- Ethylene glycol



Please contact us for more information:
www.burckhardtcompression.com
info@burckhardtcompression.com

Full Conformity to API 618 Guidelines* – Safety and Availability

● Latest technologies – for best performance

Piston rings

Decades of dry-running experience
Various own designs and materials for maximum durability
Optimized wear compensation

Packings

Applied technology based on decades of experience
Heterogenous systems allowing high pressure dry-running services
Extremely high sealing efficiency and lifetime

Main bearings

Interchangeable with big-end bearings

Guide rings

According to API 618
Pressure relieved
Very long lifetime
Optimized mounting position

Oil wiper packings

Highly efficient oil removal
Material selection according to specific application
Long lasting design for minimum lube-oil consumption

Big-end bearings

Interchangeable with main bearings

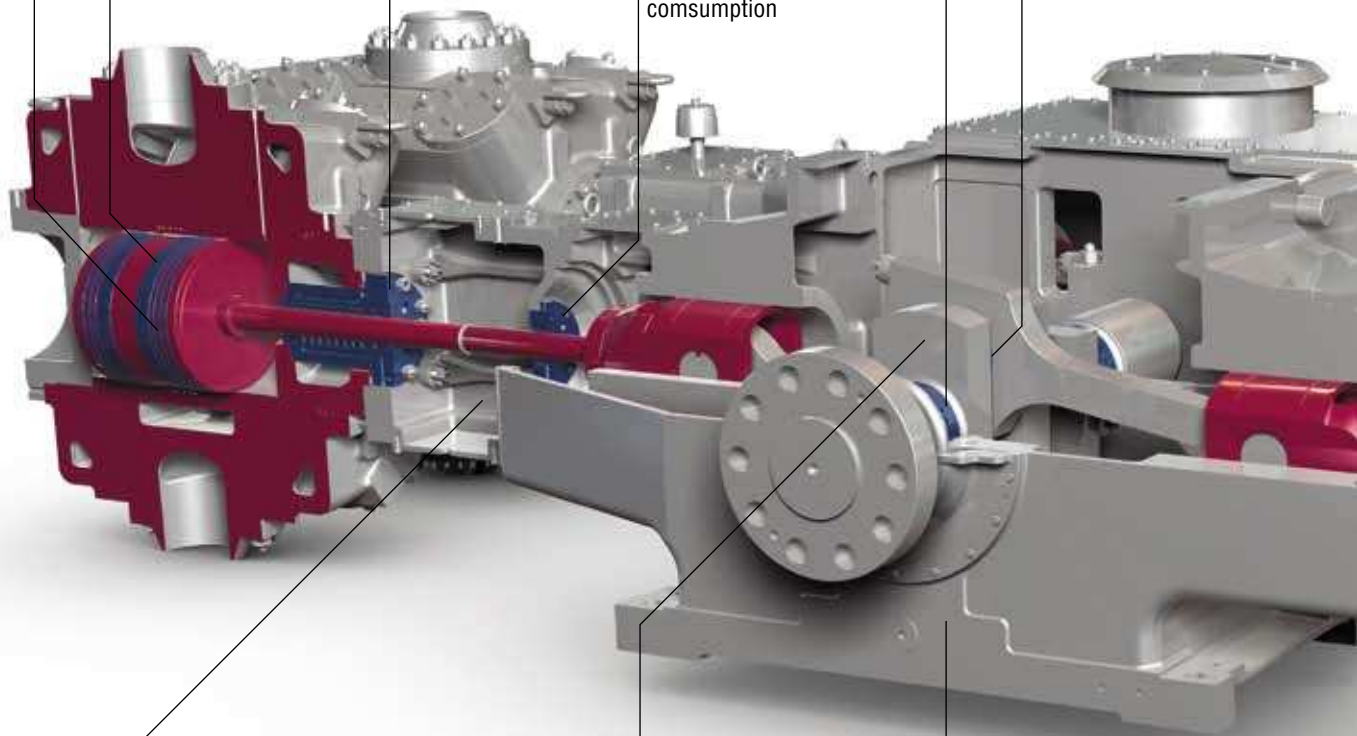

● Rugged design – for durability

Distance pieces

Single or double compartment
Vented
Purged
Pressurized

Lube-oil system (not illustrated)

According to API 618/614 or to customer requirements

Crankshaft

Forged

Frame

Robust
FEM optimized

● **In-house engineered and manufactured key components – for reliability**

Cross heads

One piece or with replaceable shoes

Piston rods

Hardened
Coated

Pistons

Wide range of designs and materials

Cylinders

Various designs and materials
Replaceable liners

Valves

Burckhardt Plate Valve™
Burckhardt Poppet Valve™
Manley® Valve, licensed by Burckhardt Compression
Over 120 years of experience in design, manufacturing and service
Selection and custom engineering according to application requirements
Maximum durability due to in-house valve technology

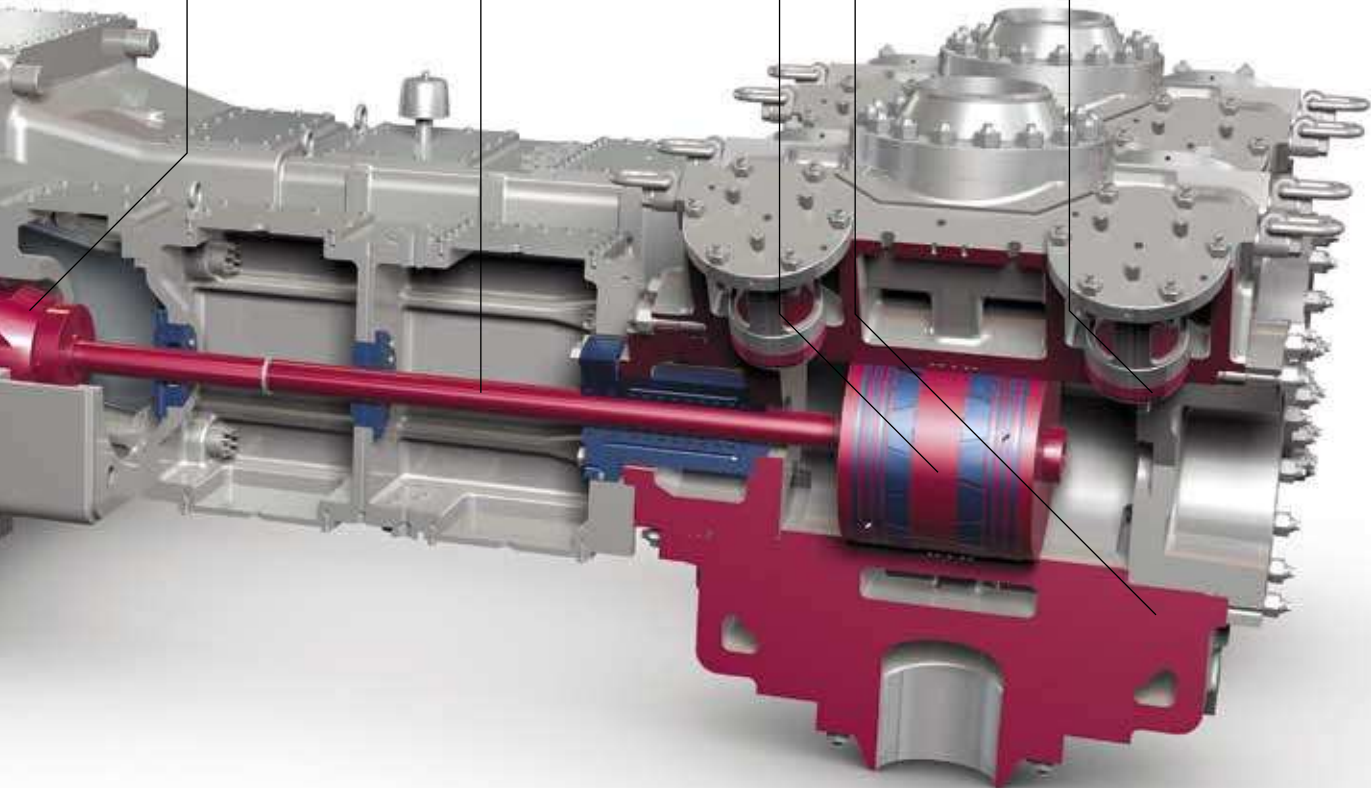

* We also offer optional customisation

Technical Data – Extensive Performance Range with a Compact Design

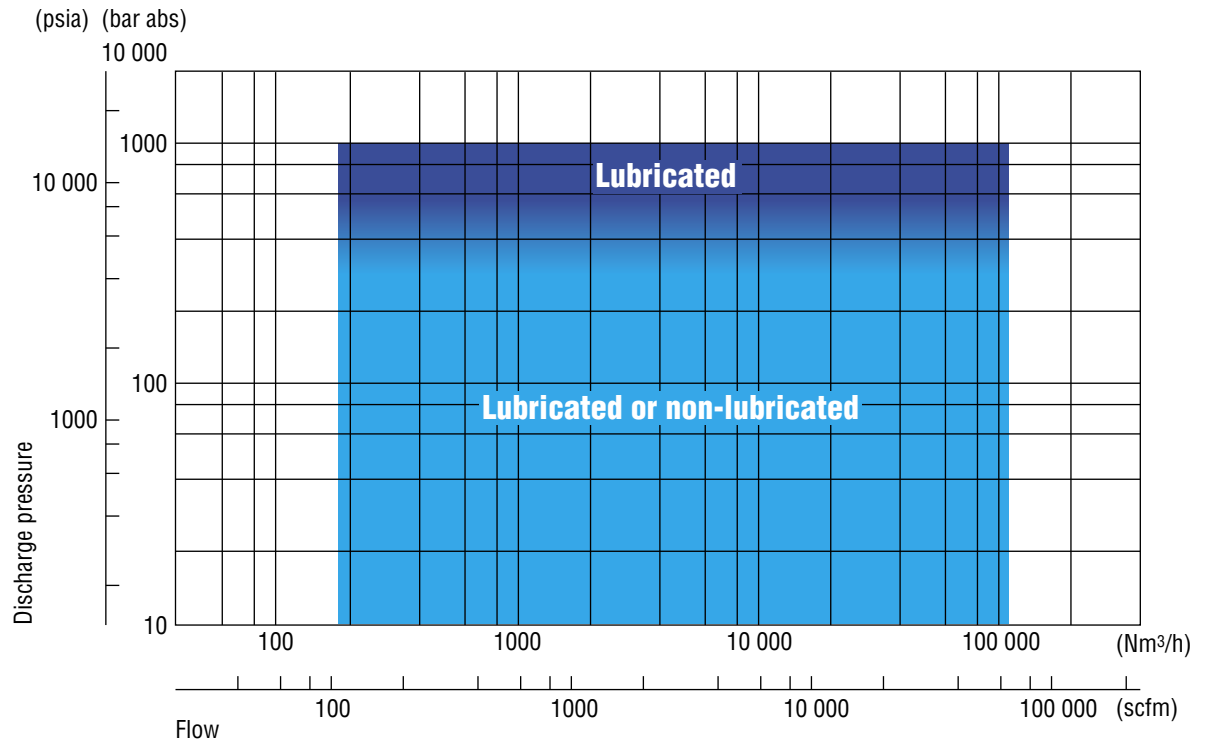

Dimensions

Type	Max. Speed [min ⁻¹]	Max. Power [kW / hp]	Width [mm / in.]	Height [mm / in.]	Length [mm / in.]		
BS	600	2400 / 3200	5600 / 220	1200 / 47	1000 / 40	2	crank
					2150 / 84	4	
					3350 / 131	6	
BX	520	5400 / 7200	7750 / 305	1390 / 54	890 / 35	2	crank
					2150 / 84	4	
					3390 / 133	6	
BA	500	9500 / 12700	8000 / 314	2200 / 86	1400 / 55	2	crank
					3200 / 125	4	
					5000 / 196	6	
BC	375	11500 / 15400	8000 / 314	2000 / 78	1600 / 62	2	crank
					3500 / 134	4	
					5400 / 212	6	

Vertical 1, 2 and 3 crank BS compressors are also available.

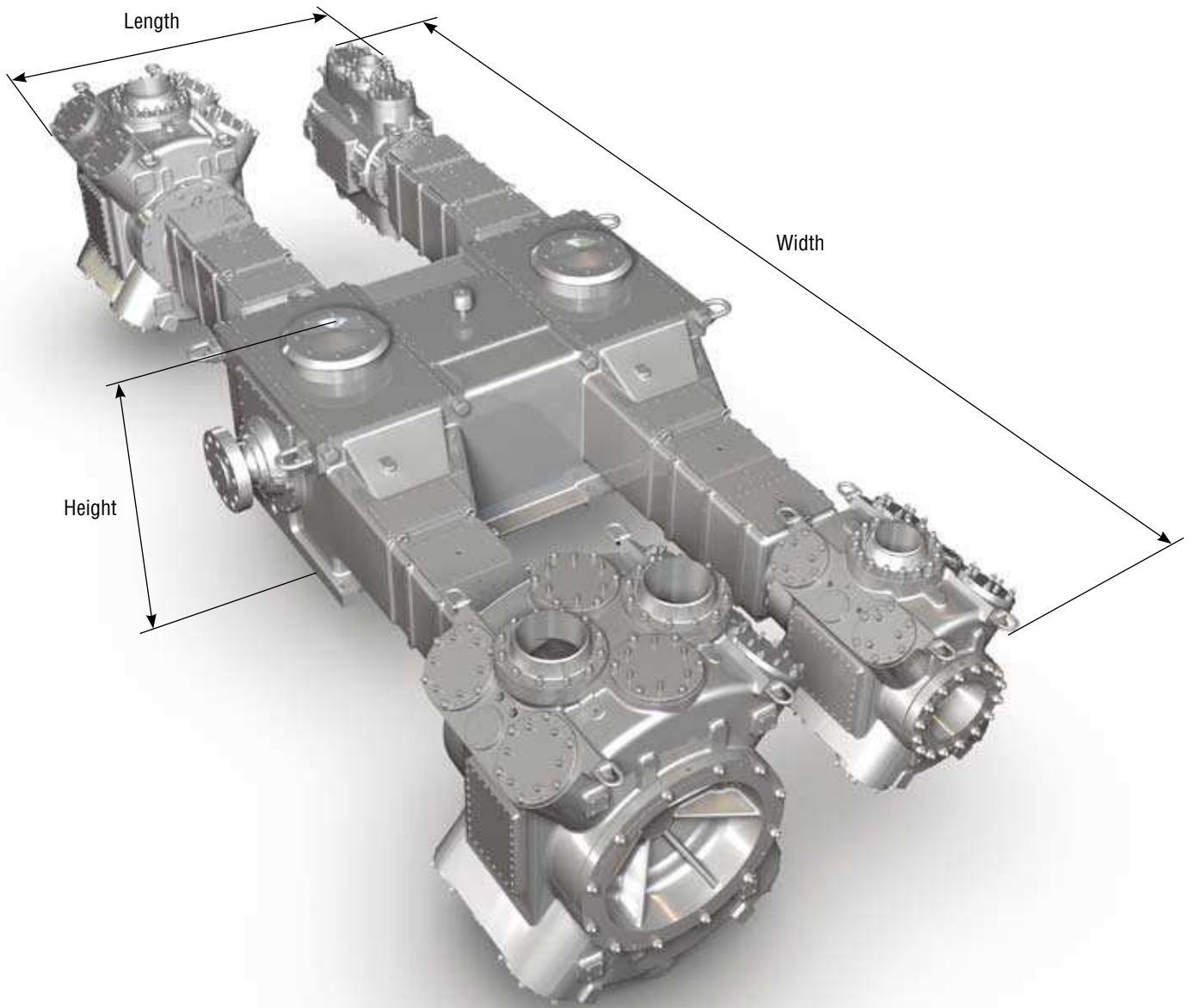

Ease of Maintenance – Substantial Added Value

Maintenance contracts – For carefree operation



Today's market environment demands the highest availability of a plant in order to maximize output and increase profitability. Reciprocating compressors play a key role within a process and therefore require long meantime between overhaul (MTBO).

Tailor made maintenance contracts to suit specific client needs are available for carefree operation.

Large openings – For easy access

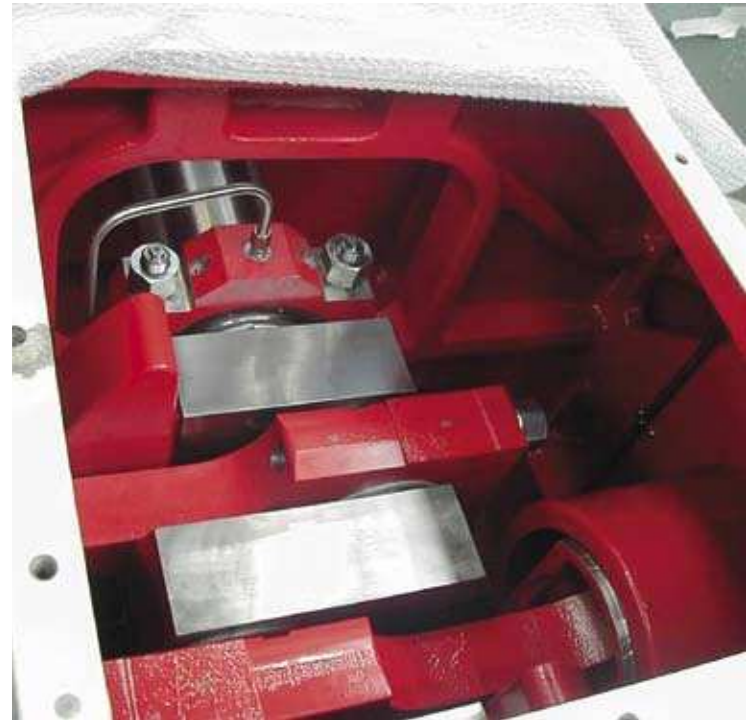

Burckhardt Compression ensures the cost effective performance of preventive and predictive maintenance. Already during the development of a new compressor we focus on serviceability by ensuring that all relevant parts can be maintained easily by providing:

- easy access to wear parts
- attractive spare parts prices
- easy ordering system
- professional parts logistics
- 24 hours technical support for trouble shooting

Ease of maintenance



On-site training – For minimum downtime



Superbolt®



Hydraulic tightening device



Please contact us for more information:
www.burckhardtcompression.com
info@burckhardtcompression.com

Burckhardt Compression – The Reciprocating Compressor Company with Thorough In-House Expertise...



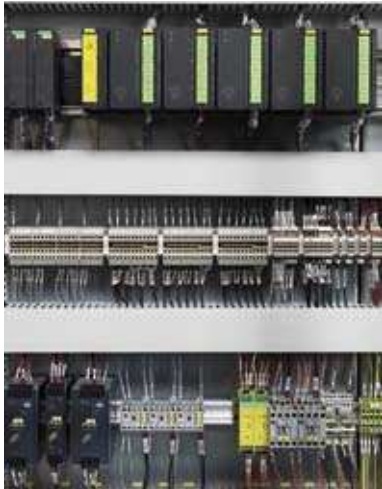
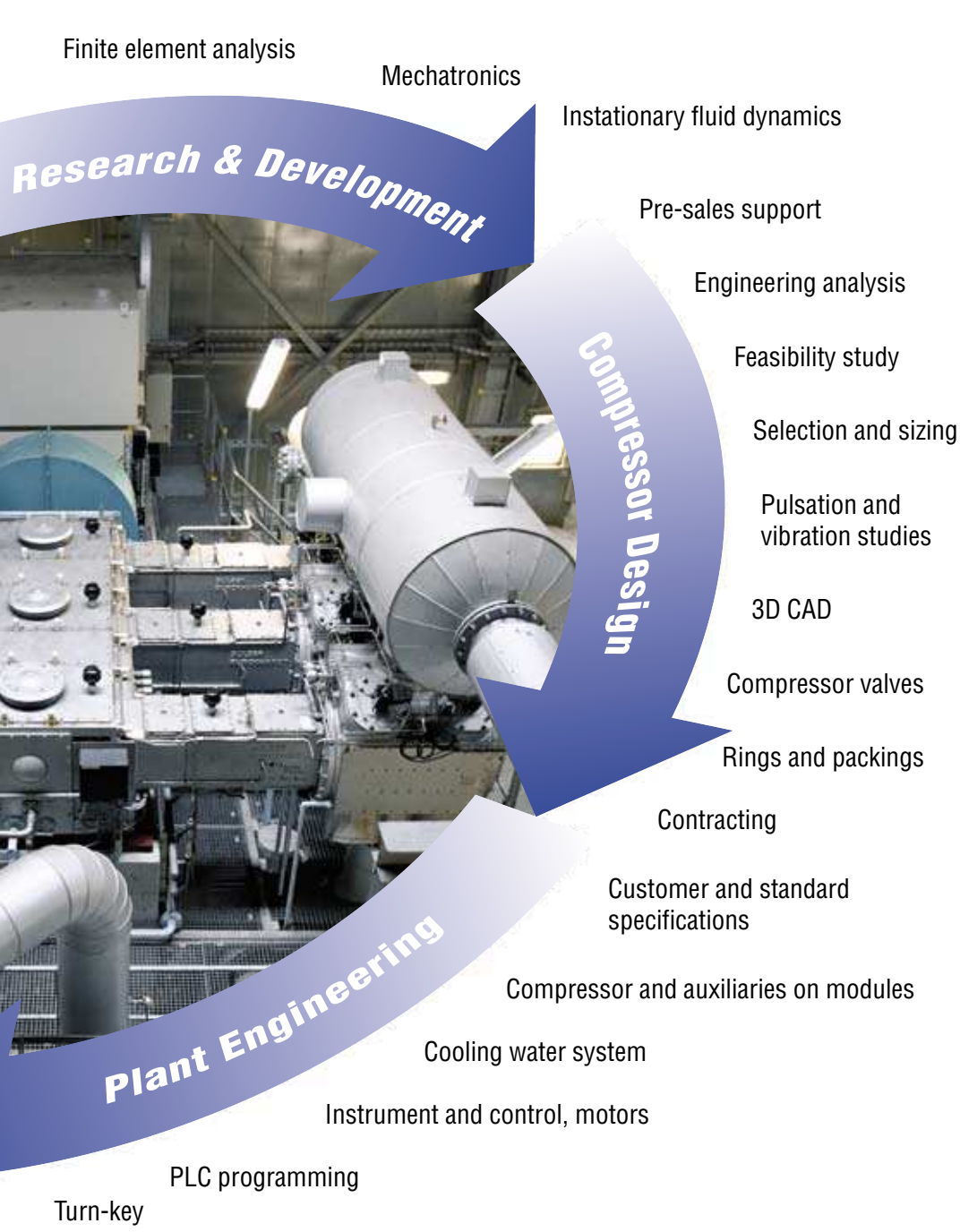

**...Ensuring a Comprehensive Service
Both for EPC Contractors and
Plant Operators**

Please contact us for more information:
www.burckhardtcompression.com
info@burckhardtcompression.com

Affordable Swiss Quality

“Quality – Performance – Costs”

The process gas compressors are the result of the broad experience gained by Burckhardt Compression over many decades. The second to none design has been accomplished in close collaboration with our customers throughout the world. Based on their needs, Burckhardt Compression provides a robust and reliable compressor of Swiss design and manufacture. Certified Swiss manufacturing, quality management and committed workforce ensure a constant high quality level.



Initial costs

Due to global sourcing, latest advanced machining technology and highly efficient manufacturing, we are able to offer compressors at very competitive prices.



Operating costs

The high quality of our compressors results in a long MTBO and in low consumption of:

- energy
- lubricants
- cooling fluids



Maintenance costs

The combination of ours and our customers' long-term experience with process gas compressors ensure the easy maintenance.

Attractive pricing of spare parts and service as required is a matter of course.



Total costs of ownership

The over-all result of our development are compressors with lowest lifecycle costs.

Plant: Industriepark Höchst
Duty: Industrial Gas
Country: Germany

“We of Infraserv Hoechst, formerly part of the biggest chemical and pharmaceutical concern Hoechst AG, have confided in Burckhardt Compression since the fifties. Compressors of Burckhardt Compression set the standard in quality, availability, economy and safety. Thanks to the compressors' ease of maintenance as

well as the reliable and wide customer support service of Burckhardt Compression our satisfaction has increased over the years. The company's broad experience and their technical competence convinced us that we have chosen the right reciprocating compressor manufacturer.”

Dr. Heinrich Lienkamp, Department Head Process Engineering, Business Unit Energies and Utilities, Infraserv GmbH & Co. Höchst KG



Please contact us for more information:
www.burckhardtcompression.com
info@burckhardtcompression.com

Customer Support Service - Enhance your Maintenance

TECHNICAL SUPPORT – Solutions for your technical questions

- Start-up support
- Project management
- Analysis of compressor performance
- Trouble shooting
- Failure analysis
- Consulting
- OEM engineering
- Increase of efficiency
- Debottlenecking

24-hours available

ENGINEERING SERVICES – Rejuvenate or tune your compressor

- Sizing
- State-of-the-art sizing tools
- Any reciprocating compressor can be modeled and calculated
- Valve dynamics
- Valves can be optimized for every application
- Finite element studies
- Stress analysis of components under dynamic load

Improve the performance of your system

COMPONENT REPAIR – Save money with us

- High pressure/low pressure packings
- Piston rod packings
- High pressure lubrication pumps
- Guide bearings
- Crossheads
- Crankshafts
- Piston rods
- Cylinders

Your benefit – our expertise

REVAMPS – Yesterday's equipment gets a new life

- Upgrades/Retrofits
- Modernizing
- Relocation of machines
- Conversion from lubricated to non-lubricated

Reliability and efficiency as today's equipment

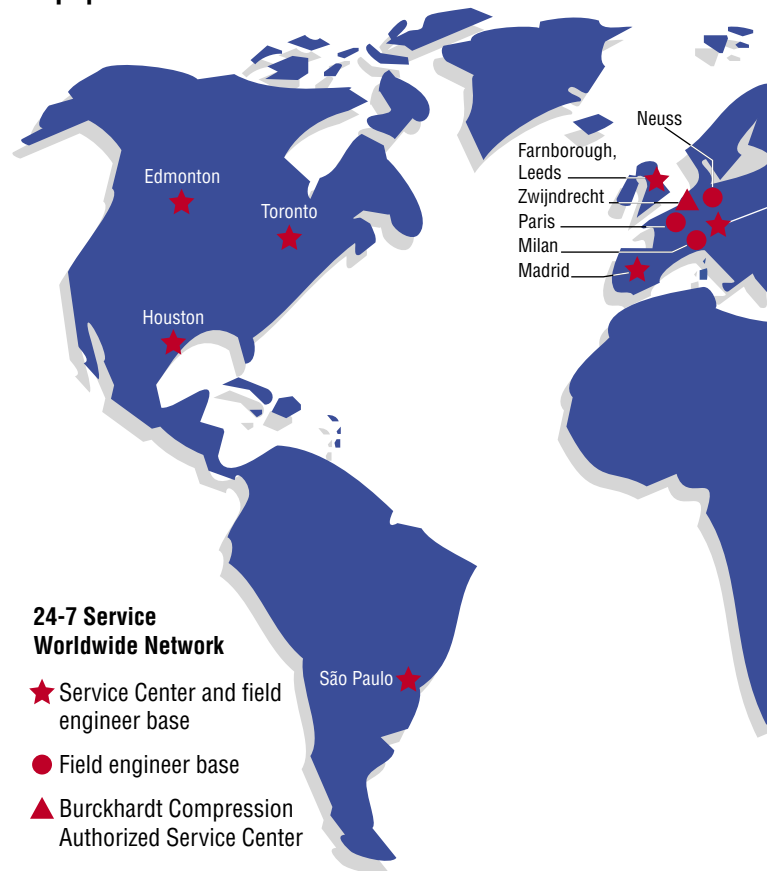

BURCKHARDT VALVE SERVICE – Rely on Burckhardt Compression as an OEM

- Analysis of valve condition
- OEM valve engineering
- Valve cleaning and overhauls
- Complete quality inspection
- State-of-the-art leak test
- Corrosion protection
- Optimal packing

You receive as-new guarantee

SPARE PARTS LOGISTICS – All out of one hand

- Express service for emergencies
- Stock recommendations to save money
- Consulting
- Spare parts contracts
- Over 16'000 parts on stock

OEM guarantee and best life cycle costs

TRAINING – Improve your knowledge in compressor operation and maintenance

- Training in Switzerland or on site
- Seminars in German, English and French – other languages on request

Efficient and economical operation

MONITORING AND DIAGNOSTICS – Extended meantime between overhaul

- OEM recommendations for system evaluation
- Condition monitoring/diagnostic systems
- Performance optimization
- Diagnostic services
- Predictive maintenance
- Full service agreements for maximum availability
- Burckhardt Compression recommends

PROGNOST

Optimize your individual key performance indicators



FIELD SERVICE – The specialists you are looking for

- On site assembly and installation
- Erection/commissioning
- Turn-key installations
- Project management on site
- Start-up
- Service contracts/preventive maintenance
- Plant overhaul/revision

Experience and efficiency to save costs

24-hours technical support:
Tel. +41 (0)52 262 53 53

Please contact us for more information:
www.burckhardtcompression.com
info@burckhardtcompression.com

Milestones of our Company History

1834 Sulzer was founded • **1844** Engineering works Burckhardt established in Basel • **1935** First Laby® – labyrinth piston compressor • **1940** First Laby® for oxygen • **1951** First Hyper compressor for IdPE production at 1500 bar • **1971** First Laby® for LNG boil-off at minus 160 °C • **1982** Merger of Sulzer and Burckhardt piston compressor businesses to form Sulzer-Burckhardt Engineering Works Ltd. • **1982** First Laby® for IIdPE and PP • **1998** First hermetically sealed, oil-free high-pressure compressor package for hydrogen • **1999** World's most powerful Hyper compressor with 23'500 kW • **2000** Consolidation of all business activities in Winterthur; manufacturing facilities and offices in Basel closed down • **2002** Legal independence through a management buyout, Sulzer-Burckhardt Engineering Works Ltd. becomes Burckhardt Compression AG • **2007** World's most powerful single frame Hyper compressor with 27'000 kW delivered

Reciprocating Compressors – The full range at your disposal



Laby® Compressor
With labyrinth sealing



Process Gas Compressor
According to API 618



Hyper Compressor
For pressures up to 3500 bar

Customer Support Service – The full range at your disposal

Your local contact

Compressors for a Lifetime



Burckhardt Compression AG · CH-8404 Winterthur, Switzerland
Tel. +41 (0)52 262 55 00 · Fax +41 (0)52 262 00 51 · 24-hours technical support Tel. +41 (0)52 262 53 53
info@burckhardtcompression.com · www.burckhardtcompression.com