

# Vertical Centrifuge - Dryer type CDR for pharmaceutical industry

Centrifuge - Dryer type CDR is made according to GMP conditions as multi-purpose machine for centrifuging (product separation from slurry) and vacuum drying of product in one working space. Agitators (discharger, cake detector, lid opening, armatures etc.) are with electro pneumatic execution.

Material of centrifuge – dryer can be made of:

- stainless steel 1.4404 (1.4435)
- special alloy 2.4602 (Hastelloy C-22)

Surface quality can be made as:

- grinded  $Ra < 0,8 \mu m$
- polished  $Ra < 0,2 \mu m$

Working cycle of centrifuge – dryer has next sequences:

- filling of basket with slurry
- centrifuging; product dewatering from maternal liquid
- product washing with washing liquid
- centrifuging; product dewatering from washing liquid
- scraping of product to baskets bottom
- milling of product in basket
- vacuum drying and heating of product
- cooling of product
- pneumatic discharging to product barrel

Cleaning of centrifuge – dryer can be made with:

- CIP nozzles for cascade cleaning
- flooding of centrifuge – dryer with cleaning liquid

Variable accessories can be:

- electric operation system
- heating – cooling system
- nitrogen system
- vacuum system
- special product barrel for pneumatic discharging of product
- technological valves, hoses



# Vertical Centrifuge - Dryer type CDR for pharmaceutical industry

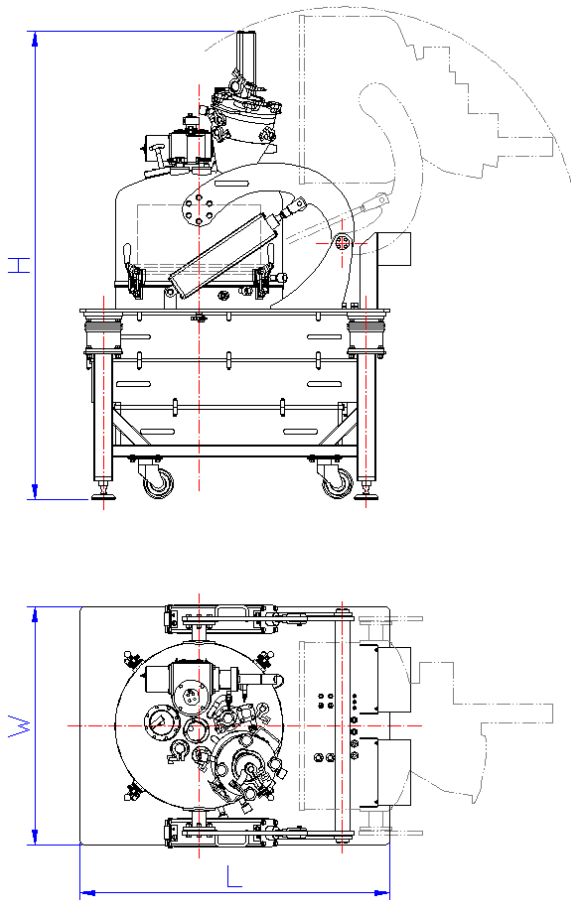

Centrifuge Dryer type		CDR 500/250	CDR 800/400	CDR 1000/500
Diameter of Basket	mm	500	800	1000
Height of Basket	mm	250	400	500
Opening diameter of Basket	mm	350	560	700
Filter surface of Basket	m <sup>2</sup>	0,393	1,005	1,571
Heated surface of Basket	m <sup>2</sup>	0,196	0,503	0,785
Useful volume of Basket	m <sup>3</sup>	0,025	0,103	0,200
Max. load of Basket	kg	30	123	240
Effective mass of Product in Basket	kg	10,5	43,1	84
Max. revolution of Basket	rpm	1900	1200	950
Centrifugal Acceleration	xg	1009	644	504
Max. unbalance weight at revolution	kg / rpm	0,6 / 1250	2,5 / 800	5,0 / 530
Min. revolution of Basket for drying	rpm	12	8	6
Max. revolution of Basket for drying	rpm	100	64	52
Min. temperature in product space	°C	-15	-15	-15
Max. temperature in product space	°C	100	100	100
Min. pressure in product space	MPa	-0,10	-0,10	-0,10
Max. pressure in product space	MPa	0,05	0,05	0,05
External dimensions H x W x L	m	2000+x1000x1300+	2750+x1600x2100+	3000+x2000x2600+
Weight of empty centrifuge dryer	kg	900	3200	5500

