

Vertical Top discharge Centrifuge type SCVT for pharmaceutical industry

Centrifuges types SCVT are made according to GMP conditions and with very variable design of centrifuge and its accessories. Agitators (discharger, cake detector, lid opening, armatures etc.) are with electro pneumatic execution.

Material of centrifuge can be made of:

- stainless steel 1.4404 (1.4435)
- special alloy 2.4602 (Hastelloy C-22)
- lining of Teflon layers (E-CTFE)

Surface quality can be made as:

- grinded $Ra < 0,8 \mu\text{m}$
- polished $Ra < 0,2 \mu\text{m}$

Top product discharging of centrifuge can be made with:

- hand made discharging
- removable top basket ring (cover) with sack
- pneumatic operated discharger
- vacuum discharging to product tank

Cleaning of centrifuge can be made with:

- CIP ball nozzles for cascade cleaning
- flooding of centrifuge with cleaning liquid

Variable design of centrifuge and its accessories can be:

- main electric motor with up or down position (+ cover for external ventilation for clean room)
- equipment for nitrogen blowing
- equipment for residual heel removing of product from basket
- equipment for suspension way (flow measuring, valves, compensators, hoses etc.)
- equipment for rinsing liquid way (flow measuring, valves, compensators, hoses etc.)
- equipment for product way (exhaust pipe, valves, compensators, vacuum tank etc.)
- equipment for liquid way (siphon, cyclone, tank with pump, valves, compensators etc.)
- stand of centrifuge



Vertical Top discharge Centrifuge type SCVT for pharmaceutical industry

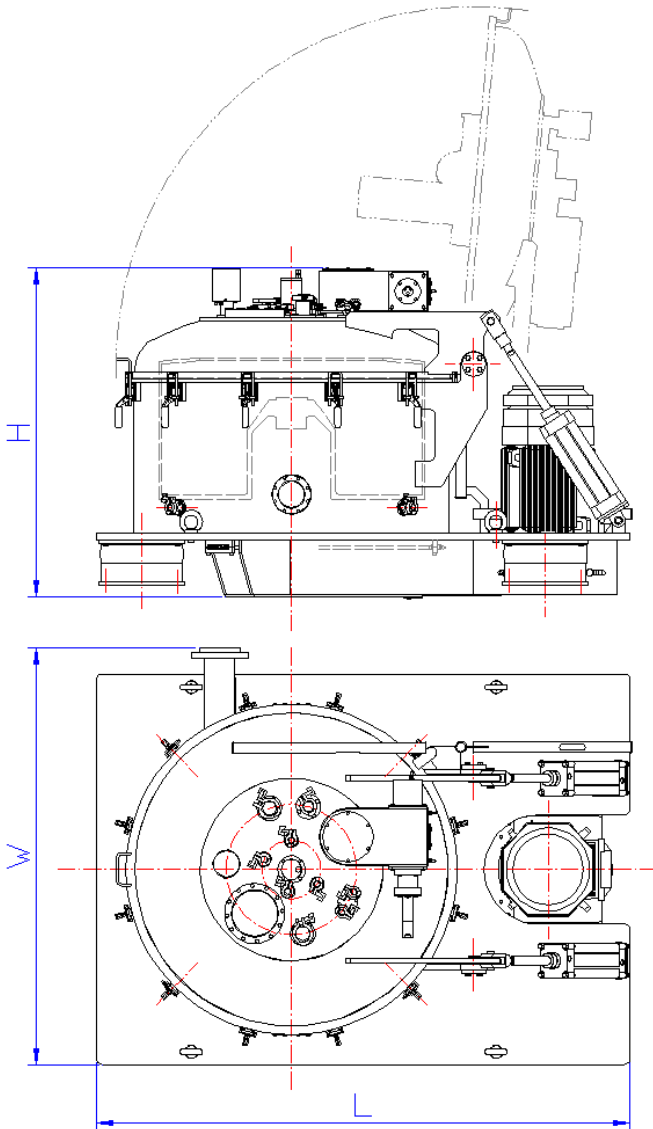

Centrifuge type		SCVT 630/320	SCVT 800/400	SCVT 1000/500
Diameter of Basket	mm	630	800	1000
Height of Basket	mm	320	400	500
Opening diameter of Basket	mm	440	560	700
Filter surface of Basket	m ²	0,633	1,005	1,571
Useful volume of Basket	m ³	0,051	0,103	0,200
Max. load of Basket	kg	64	128	250
Max. revolution of Basket	rpm	1900	1500	1200
Centrifugal Acceleration	xg	1271	1006	805
Max. unbalance weight at revolution	kg / rpm	1,5 / 1250	3,0 / 1000	5,0 / 800
Drive power	kW	4,0 - 7,5	5,5 - 11	11 - 22
External dimensions H x W x L	m	850+x1100x1350	1050+x1300x1650	1250+x1600x2100
Weight of empty centrifuge	kg	650+	1000+	2000+

