

SULTRADE

Horizontal Peeler Centrifuges SCH

Applications

Horizontal centrifuges are widely used in chemical, food and pharmaceutical industry.

Design

Our horizontal centrifuges can be made from various material i.e. Stainless steel 1.4404, 1.4571 or other, Duplex 1.4462 or Hastelloy 2.4602

Coating with hallar E-CTFE is also possible

Variable design of centrifuges and its accessories can be made according the customers need.

We offer various range of peripheral components.

Service and SP

We provide fast and reliable service together with spare parts.



SULTRADE

Horizontal Peeler Centrifuges SCH

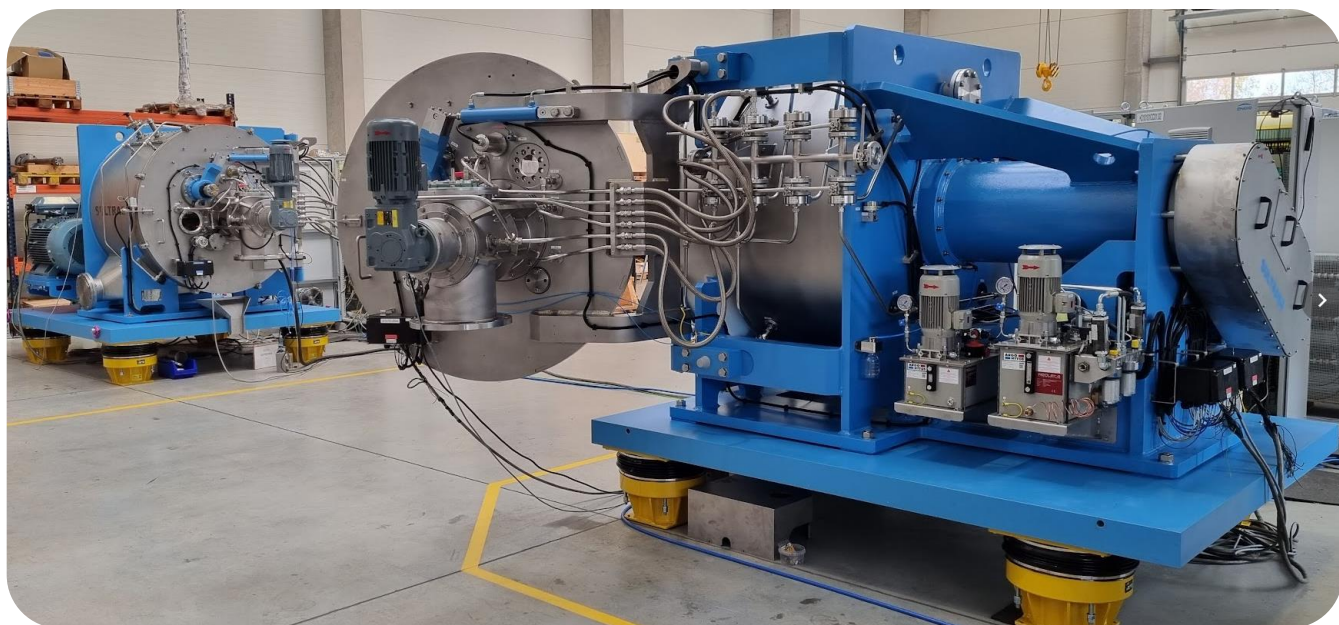
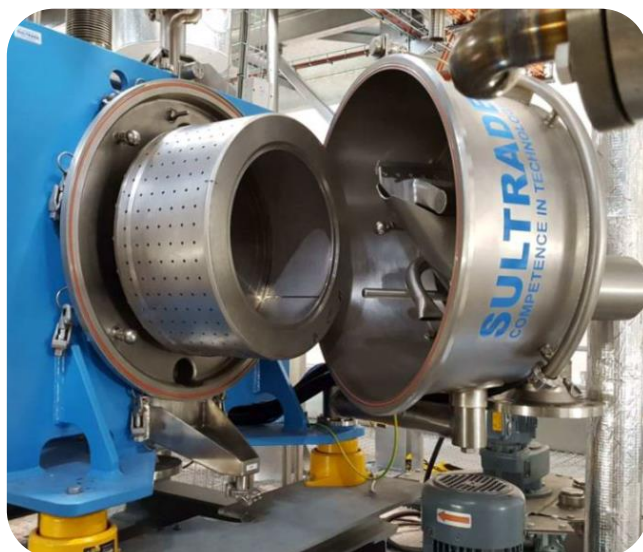
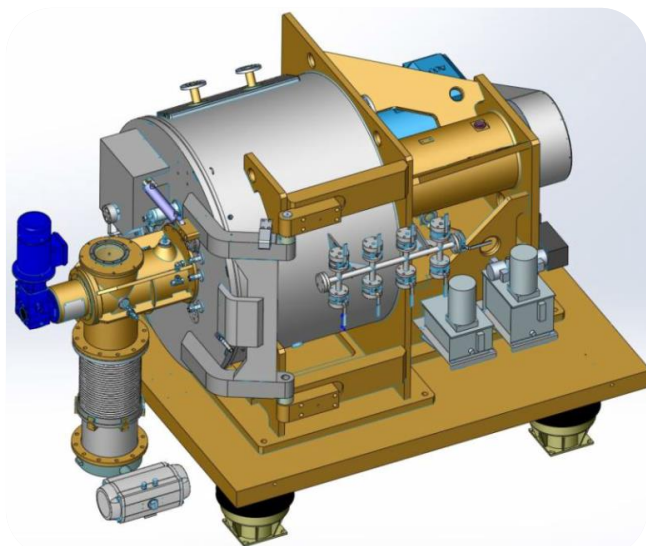

Whether you need spare parts, rentals, local service, repairs or upgrades, SULTRADE is your partner to fulfill all your requirements.

Centrifuge type	SCH 400/180	SCH 800/400	SCH 1000/500	SCH 1250/800	SCH 1600/1000	SCH 2000/1000
Basket diameter (mm)	400	800	1000	1250	1600	2000
Basket height (mm)	180	400	500	800	1000	1000
Basket filtration layer (m2)	0,226	1,005	1,571	3,142	5,027	6,283
Active basket volume (m3)	0,01	0,088	0,172	0,427	0,875	1,255
Maximum basket filling (kg)	17,5	110	215	530	1095	2200 (1100)
Maximum basket speed (min-1)	3000	1900	1500	1200	950	660 (825)
Maximum gravity factor (xg)	2012	1614	1257	1006	807	487 (761)
Driving electric motor (kW)	4	30	37	75	110	110
Weight of empty centrifuge (kg)	500	4300	5000	9000	17000	22000